

SIRCO AC

Load Break Switches from 200 to 1600 A
Solar systems at 800 VAC

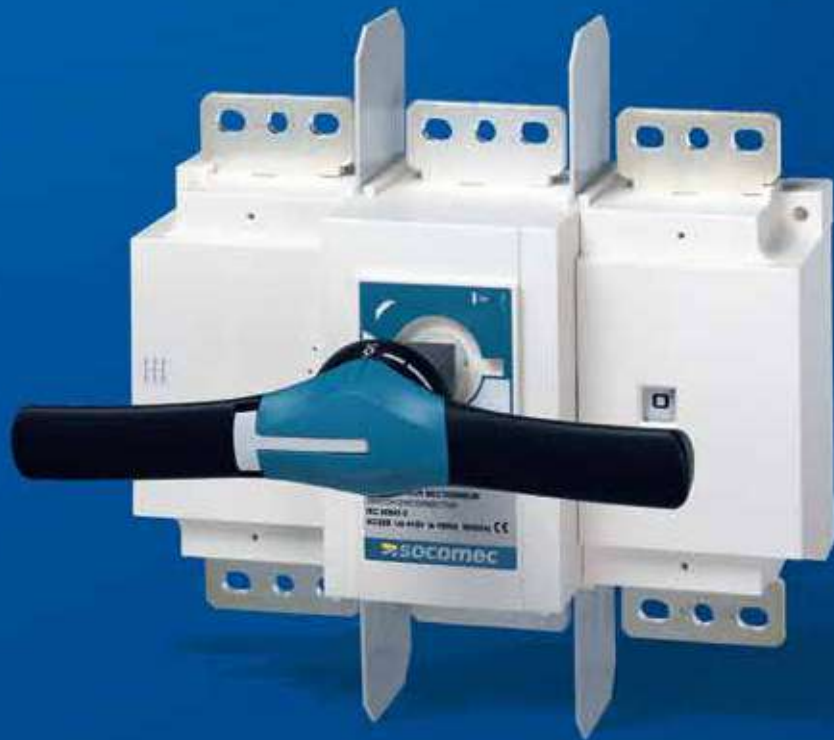

FLEXIBLE
RELIABILITY DESIGNED-IN
SAFE OPERATION
EASY INSTALLATION

Socomec's unrivalled electrical switching technology has been deployed in the most challenging applications around the world since 1922.

SIRCO AC - developed to ensure breaking performance and system robustness in solar AC applications - are multipolar load break switches with manual and positive break indication. The switches break and make under load conditions and provide safety isolation for all low AC voltage circuits up to 800 VAC.

When **energy** matters

 **socomec**
Innovative Power Solutions

SIRCO AC

Load Break Switches from 200 to 1600 A
Solar systems at 800 VAC

Advantages

- **Flexible**
 - Complete range from 200 A to 1600 A at 800 VAC.
- **Reliability designed-in**
 - Rapid opening and closing - combined with arcing chambers - ensure improved breaking performance.
 - Double breaking per pole - via proven sliding system - provides durability and high short-circuit current withstand.
 - Corrosion and pollution resistant thanks to the use of glass fibre reinforced polyester.
- **Safe operation**
 - The position indicator – located directly on the moveable contacts bar - is easy to view under all circumstances.
 - Safety, quality and reliability testing.
- **Easy installation**
 - External terminal design facilitates connection:
 - Good centre-to-centre distance (up to 65 mm).
 - Copper connection up to 240 mm².
 - Large range of accessories to facilitate integration and operation.

Compliance with relevant standards

- CEI 60947-3
- EN 60947-3
- UL98 C (please consult us)



Applications

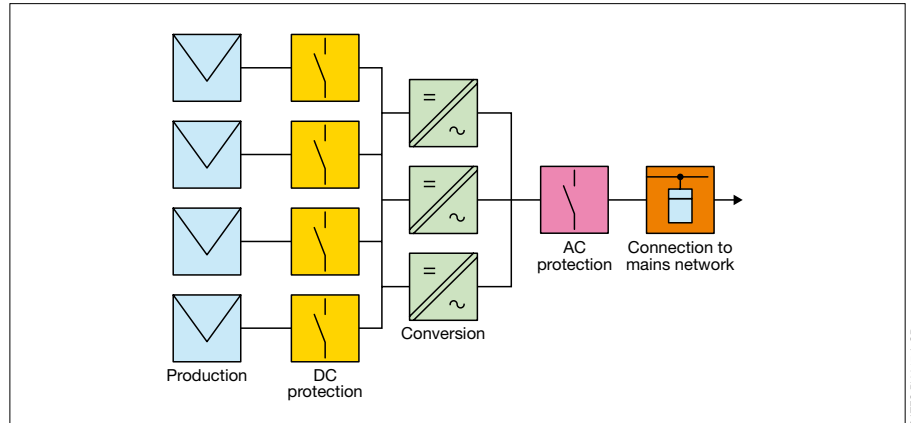

SIRCO AC load break switches are both reliable and flexible - with all the necessary credentials to perform in the most challenging operating conditions, such as solar systems equipped with strings inverters. SIRCO AC has been designed specifically for all heavy duty applications up to 800 VAC. With the potential to be deployed as output or input disconnectors switches, SIRCO's wide range of accessories make it suitable for any environment.

SIRCO AC - 800 VAC

Rating (A)	Frame size	3 P reference	4 P reference
200 A	B4	26A0 3020	26A0 4020
250 A	B4	26A0 3025	26A0 4025
315 A	B4	26A0 3031	26A0 4031
400 A	B5	26A0 3040	26A0 4040
630 A	B5	26A0 3063	26A0 4063
800 A	B6	26A0 3080	26A0 4080
1000 A	B7	26A0 3100	26A0 4100
1600 A	B8	26A0 3160	26A0 4160

HEAD OFFICE

SOCOMEK GROUP

SAS SOCOMEK capital 10633 100 €
R.C.S. Strasbourg B 548 500 149
B.P. 60010 - 1, rue de Westhouse
F-67235 Benfeld Cedex
Tel. +33 3 88 57 41 41 - Fax +33 3 88 57 78 78
info.scp.isd@socomec.com

YOUR DISTRIBUTOR / PARTNER

www.socomec.com

